

# EXHIBIT "A"

5 Pages

# ELECTRICAL LEGEND

- ⊕ SINGLE POLE SWITCH
- ⊕<sup>3</sup> THREE WAY SWITCH
- ⊕<sup>4</sup>
- ⊕ 120V DPLX OUTLET
- SURFACE MTD. FLUOR
- ⏏ EMERGENCY LIGHT
- ⊗ PADDLE FAN

ALL OUTLETS TO BE GF1 / WEATHERPROOF  
 ALL SWITCH LOCATIONS TO BE LOCATED IN EXISTING BUILDING

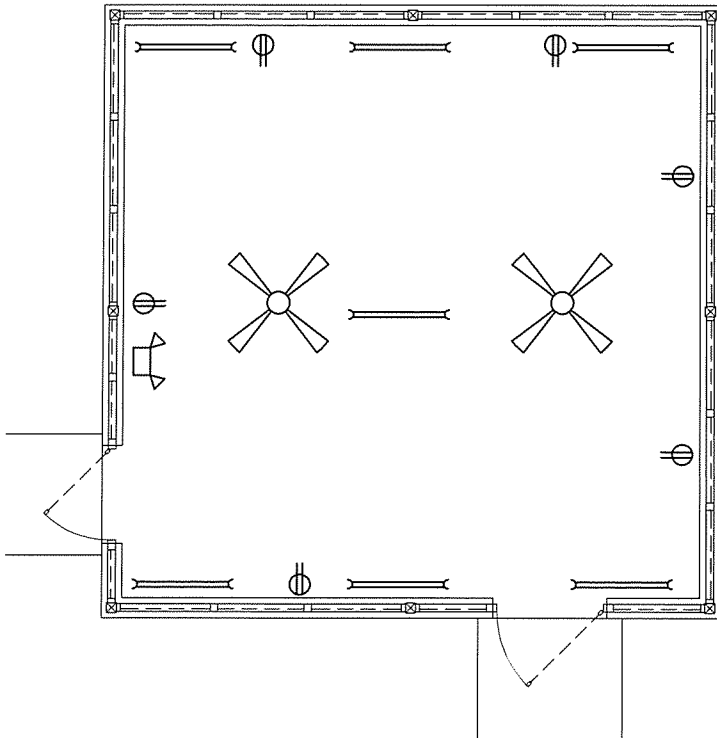

# ELECTRICAL PLAN

Scale: 1/4" = 1'-0"

LCM Engineering, PLLC  
 5294 SUMMERLIN COMMONS WAY  
 FORT MYERS, FLORIDA 33907  
 (239)590-0263 EB/CA-29355



MEMBER:  
 FLORIDA  
 STRUCTURAL  
 ENGINEERS  
 ASSOCIATION

CONCIERGE CONSTRUCTION SERVICES  
 OASIS YOUTH SHELTER

|           |        |       |           |       |   |
|-----------|--------|-------|-----------|-------|---|
| PROJ. NO. | 19-206 | DATE: | 1-28-2019 | REV.  | - |
| BY:       | DAUN   | CHKD  |           | APPD. |   |

E1

OF 6

**REAR ELEVATION**  
Scale: 1/8" = 1' 0"

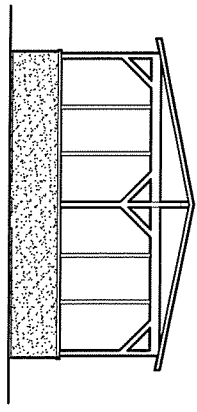

**LEFT ELEVATION**  
Scale: 1/8" = 1' 0"

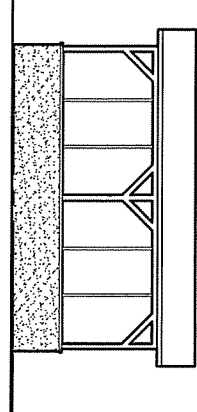

**RIGHT ELEVATION**  
Scale: 1/8" = 1' 0"

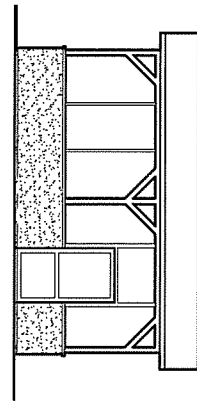

**FRONT ELEVATION**  
Scale: 1/4" = 1' 0"

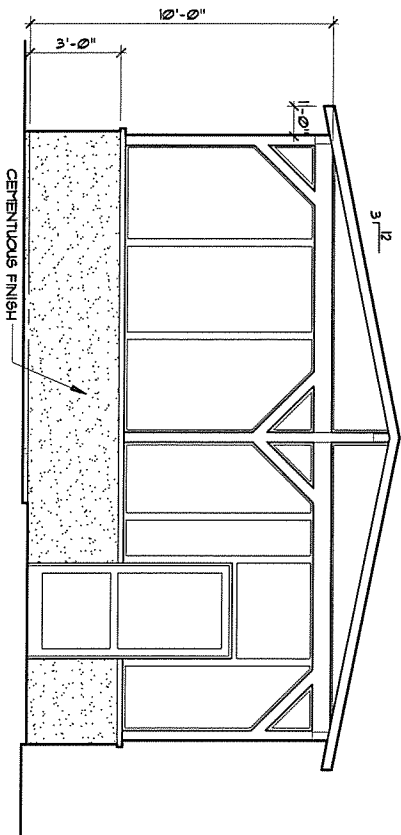

LCM Engineering, PLLC  
5294 SUMMERLIN COMMONS WAY  
FORT MYERS, FLORIDA 33907  
(239)590-0263 EB/CA-29355



MEMBER:  
FLORIDA  
STRUCTURAL  
ENGINEERS  
ASSOCIATION

CONCIERGE CONSTRUCTION SERVICES  
OASIS YOUTH SHELTER

|           |        |       |           |       |   |
|-----------|--------|-------|-----------|-------|---|
| PROJ. NO. | 19-206 | DATE: | 1-28-2019 | REV.  | - |
| BY:       | DAUN   | CHKD  |           | APPD. |   |

S2

OF 6

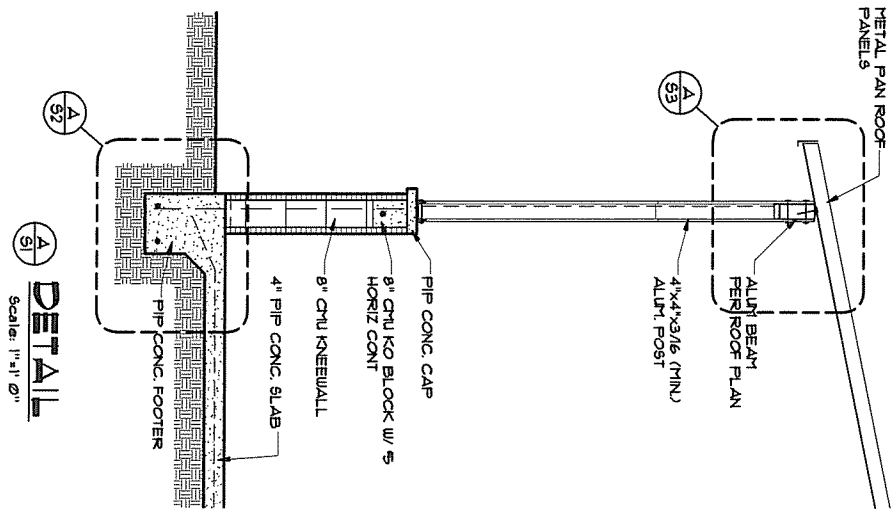

**DETAIL**  
Scale: 1/4" = 1' 0"

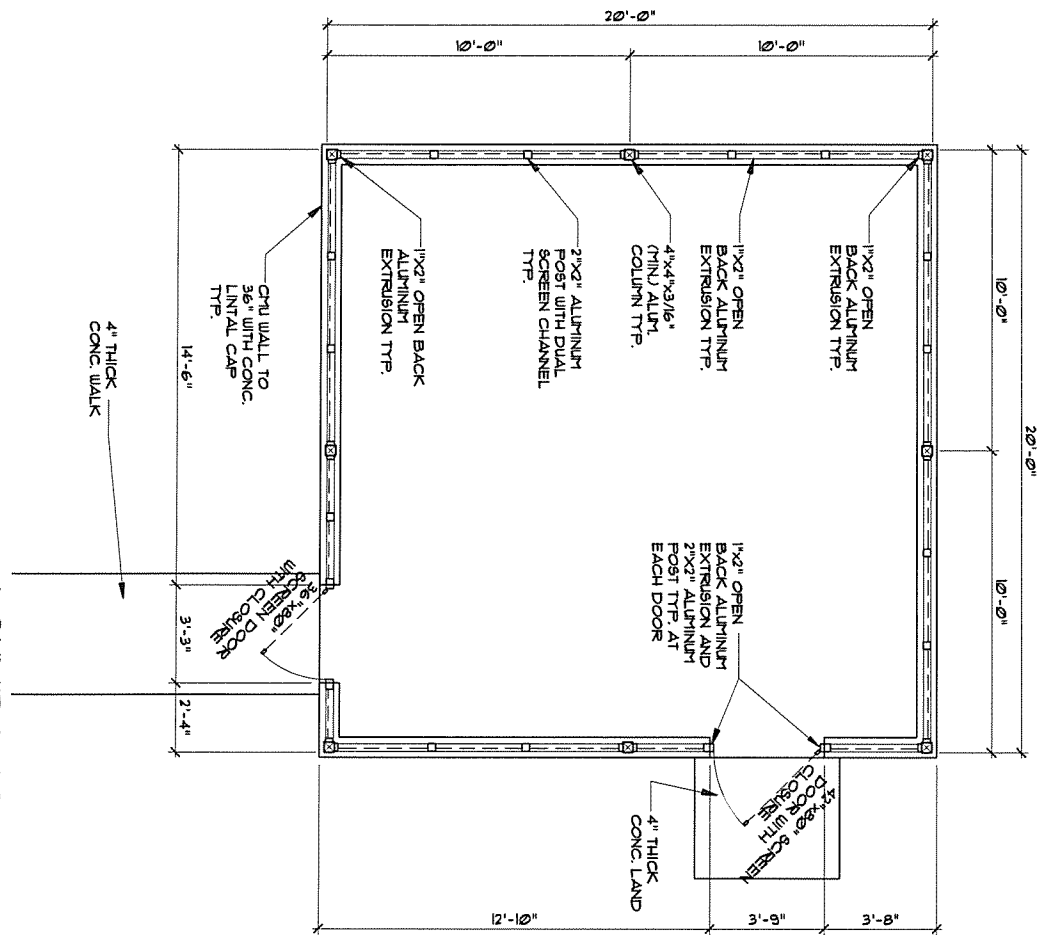

**FOUNDATION PLAN**  
Scale: 1/4" = 1' 0"

LCM Engineering, PLLC  
5294 SUMMERLIN COMMONS WAY  
FORT MYERS, FLORIDA 33907  
(239)590-0263 EB/CA-29355



MEMBER:  
FLORIDA  
STRUCTURAL  
ENGINEERS  
ASSOCIATION

CONCERGE CONSTRUCTION SERVICES  
OASIS YOUTH SHELTER

|           |        |       |           |         |
|-----------|--------|-------|-----------|---------|
| PROJ. NO. | 19-206 | DATE: | 1-28-2019 | REV. -- |
| BY:       | DAUN   | CHKD  | APPD.     |         |

S1

OF 6

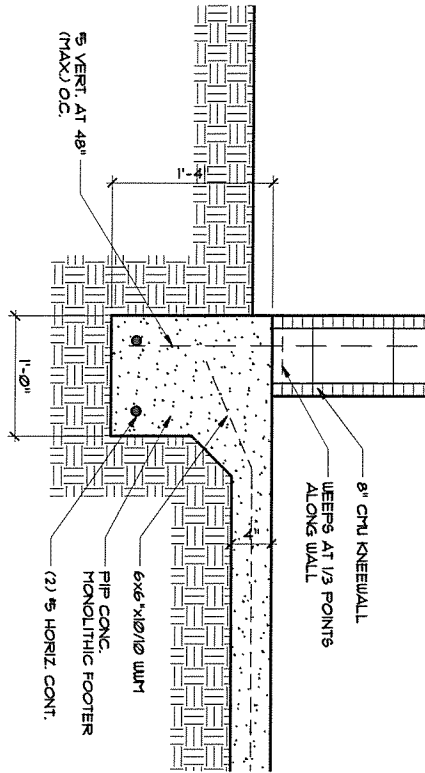

**DETAIL**  
Scale: 1"=1'-0"

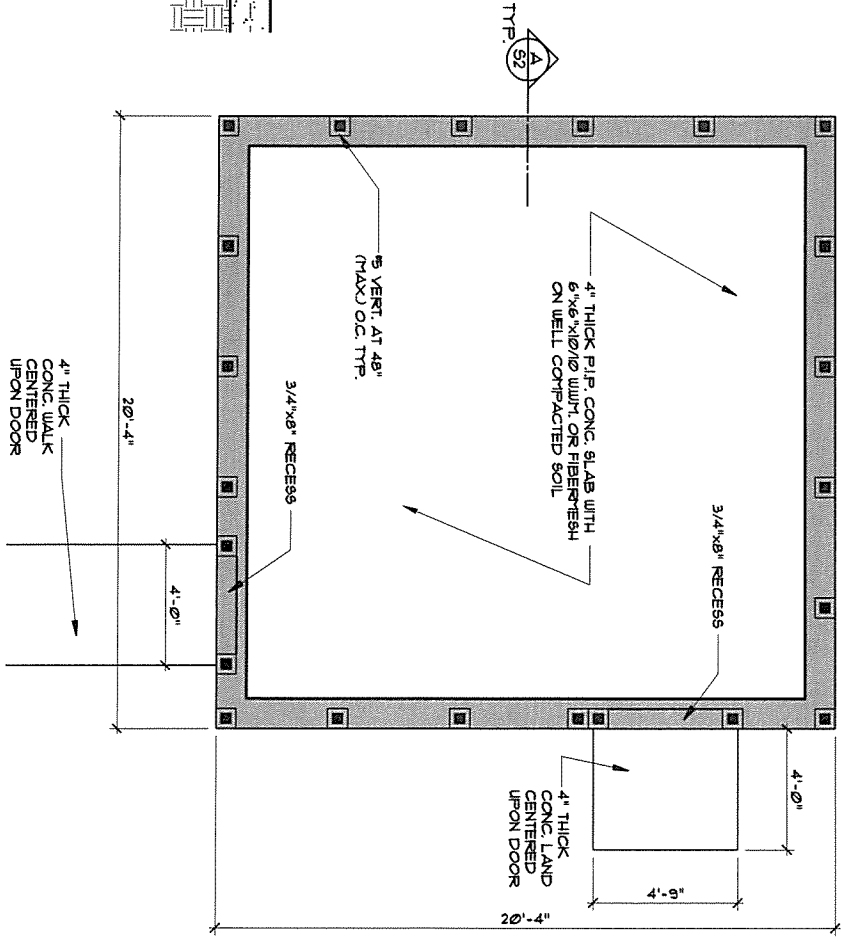

**FOUNDATION PLAN**  
Scale: 1/4"=1'-0"

|  |   |   |                         |                 |                   |
|--|---|---|-------------------------|-----------------|-------------------|
| <b>LCM Engineering, PLLC</b><br>5294 SUMMERLIN COMMONS WAY<br>FORT MYERS, FLORIDA 33907<br>(239)590-0263 EB/CA-29355 | MEMBER-FLORIDA STRUCTURAL ENGINEERS ASSOCIATION | <b>CONCIERGE CONSTRUCTION SERVICES</b><br>OASIS YOUTH SHELTER |                         |                 | <b>S3</b><br>OF 6 |
|  |   | PROJ. NO. 19-206<br>BY: DAUN                                  | DATE: 1-28-2019<br>CHKD | REV. -<br>APPD. |                   |

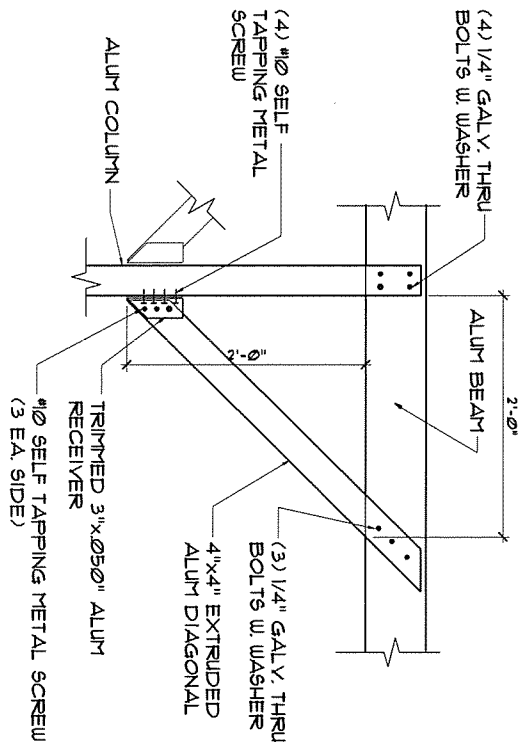

**A**  
53  
**TYP. DETAIL**  
Scale: 1"=1' 0"

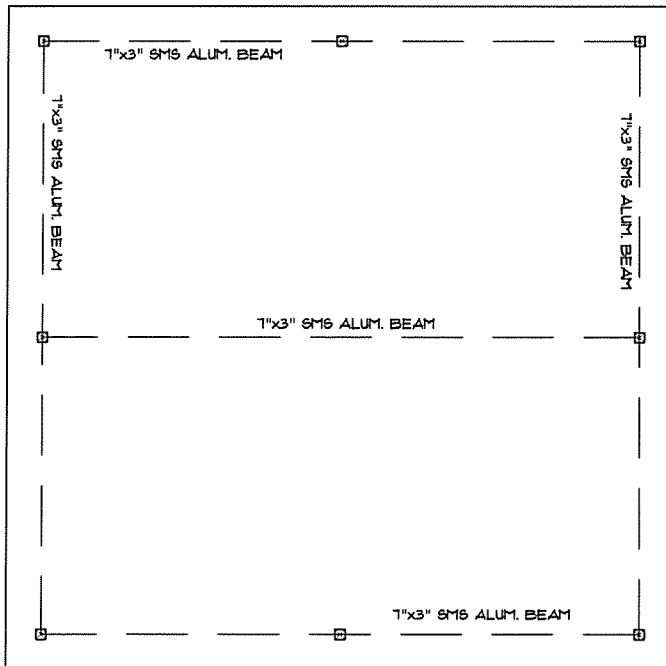

**ROOF PLAN**  
Scale: 1/4"=1' 0"

LCM Engineering, PLLC  
5294 SUMMERLIN COMMONS WAY  
FORT MYERS, FLORIDA 33907  
(239)590-0263 EB/CA-29355



MEMBER:  
FLORIDA  
STRUCTURAL  
ENGINEERS  
ASSOCIATION

CONCIERGE CONTRUCTION SERVICES  
OASIS YOUTH SHELTER

|                  |                 |        |
|------------------|-----------------|--------|
| PROJ. NO. 19-206 | DATE: 1-28-2019 | REV. - |
| BY: DAUN         | CHKD            | APPD.  |

S4

OF 6